

# PV-1010 Easy Check

WindowsCE.NET Fixed Computer



- Superior CPU performance
- Powerful Microsoft® Windows® CE.NET 5.0 operating system
- Smart and rugged design
- 5.7" TFT VGA color display with touch panel
- Expandable interfaces for extra storage
- Supports in Power over Ethernet (PoE) technology
- Two stereo speaker with multimedia capability
- Satisfied functionalities to accomplish all possibilities
- Fully flexibility in programming and memory extension



**GLACIER COMPUTER LLC**

10 Northern Blvd - Amherst NH 03031 - 603.882.1560 - [www.glaciercomputer.com](http://www.glaciercomputer.com)



## [Dimensions]

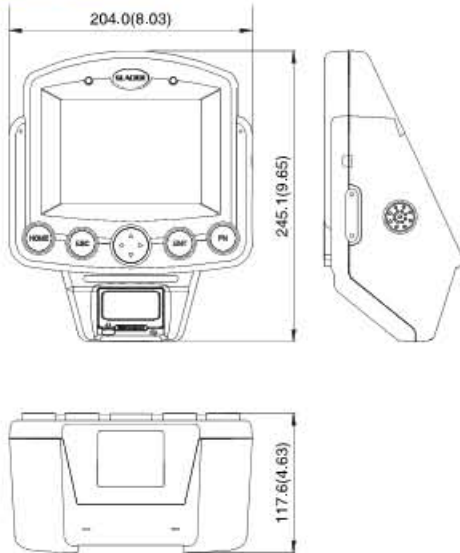

Unit: mm(inch)

## [Scan Field]

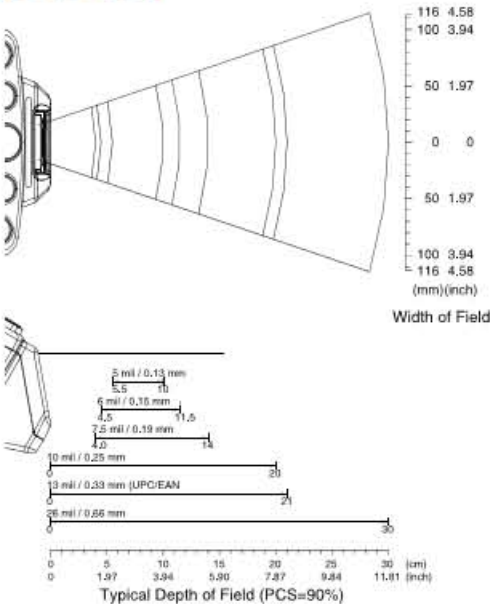

## [Accessories]

- AC adaptor DC 9V, 2A
- RS-232 cable, RJ45 converts to 9 pin D-sub female
- USB cable, B type converts to A type (optional)
- Wall-mounting kit
- Wall-mounting outrigger (optional)



## [Specifications]

### SYSTEM

|                              |  |
|------------------------------|--|
| <b>CPU</b>                   | Intel PXA 270 520 MHz processor                                      |
| <b>Operating System</b>      | Microsoft® Windows® CE.NET 5.0                                       |
| <b>RAM</b>                   | 64MB, upgradeable to 128MB   |
| <b>ROM</b>                   | 64MB   |
| <b>Display (LCD)</b>         | 5.7" TFT VGA 640x480 color display with touch panel                  |
| <b>Back Light</b>            | LED back light   |
| <b>Keypads &amp; Buttons</b> | Five keys: HOME, ESC, Up/Right/Down/Left, ENT (Enter), FN (Function) |
| <b>Audio</b>                 | Two stereo speaker   |

### INTERFACE

|                 |   |
|-----------------|---|
| <b>Ethernet</b> | 10/100 Mbps Ethernet (PoE)  |
| <b>USB</b>      | USB version 1.1 Host for external device (back);<br>USB version 1.1 Client for external device (side) |
| <b>RS-232</b>   | Programmable up to 115,200 bps  |

### EXPANSION SLOT

|                         |  |
|-------------------------|--|
| <b>C/F Card Slot</b>    | One compact flash Type II card slot (for data storage only)        |
| <b>SD I/O Card Slot</b> | One SD I/O card slot, for extended to Bluetooth® or IEEE 802.11b/g |

### POWER

|                       |  |
|-----------------------|--|
| <b>AC Adaptor</b>     | 9V-DC, 2A, 110V/220V input AC auto selecting   |
| <b>Backup Battery</b> | 3.7V, 120mAH, Lithium-Ion rechargeable battery |

### SCANNER

|                   |   |
|-------------------|---|
| <b>1D Scanner</b> | A-50M Omnidirectional Laser Scan Module |
|-------------------|---|

### PHYSICAL

|                   |                                   |
|-------------------|-----------------------------------|
| <b>Dimensions</b> | (L)245.1 × (W)204.0 × (H)117.6 mm |
| <b>Weight</b>     | Approx. 1,400 g                   |

### ENVIRONMENTAL

|                              |                               |
|------------------------------|-------------------------------|
| <b>Operating Temperature</b> | 0°C – 50°C (32°F – 122°F)     |
| <b>Storage Temperature</b>   | -10°C – 60°C (14°F – 140°F)   |
| <b>Operating Humidity</b>    | 10% – 70% RH (non-condensing) |
| <b>Storage Humidity</b>      | 5% – 70% RH (non-condensing)  |

### REGULATORY

|            |                        |
|------------|------------------------|
| <b>EMC</b> | CE & FCC Part 15B, 15C |
|------------|------------------------|

## [Model Selections]

| Model    | Scanner            | WLAN       | Ethernet | Bluetooth® |
|----------|--------------------|------------|----------|------------|
| Z-7010BA | 1D omnidirectional | Expandable |          | Expandable |



**GLACIER COMPUTER LLC**

10 Northern Blvd - Amherst NH 03031 - 603.882.1560 - www.glaciercomputer.com

